

ROCK VALVE™

STATIONARY CONCRETE PUMPS

SP 500 / SP 750-15 / SP 750-18
SP 1000 / SP 1000HP / SP 1250 / SP 2000



SCHWING®

THE CONCRETE, SHOTCRETE OR GROUT PUMPS



Invest in an all-hydraulic concrete pump that incorporates big pump features into a compact, economical package. The SP Series pumps are excellent entry level, all-around performers as well as seasoned professional machines pumping grout, shotcrete and structural concrete with outputs up to 118 yards per hour and pumping pressure up to 1568 psi. At the heart of these concrete pumps is the Rock Valve™. With the lowest operating cost per yard, the Rock Valve™ is your guarantee of profitable pumping of the harshest mixes. This is the only sequencing valve that is completely rebuildable adding to long term reliability and maximum utilization.

Because your SP model is patterned on larger Schwing models, you are guaranteed legendary reliability that has been proven on thousands of projects. Whether your pump is your livelihood or part of a larger equipment fleet, purchase with the confidence that only a Schwing can provide.

This open loop all-hydraulic concrete pump sets the standard for fuel-efficiency, reliability and performance. The **Rock Valve™** pumps the harshest mixes at the lowest operating cost and cleans up faster with less water. Symmetrical Switching equalizes pressures in the concrete pump for smoother, quieter operation.

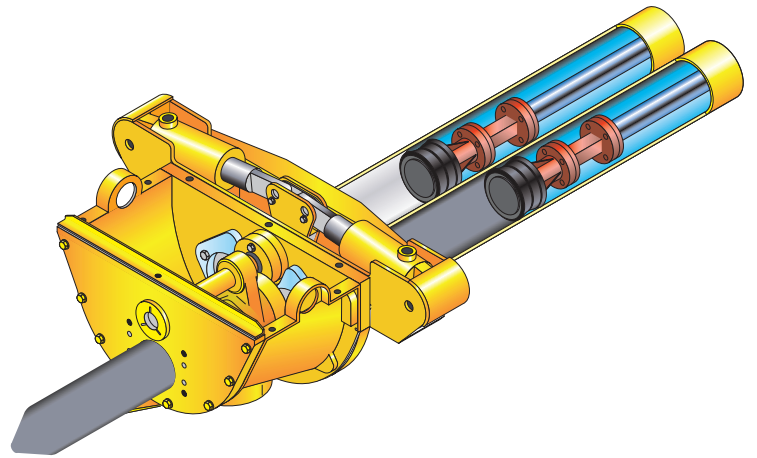

Schwing Control Technology (SCT) includes electric throttle and stroke limiter for precise volume control. Control panel uses digital display and LED lighting for easy operation and diagnostic support.



Hydraulic Oil Cooler controls heat during continuous concrete pumping providing proven cooling performance.



CAT Diesel Engines for long-term reliability. Choose from Tier 4 Final or Tier 3 models for export to comply with your local emissions standards. Electric motors available for all models.



Remote Control frees the operator to monitor pumping progress. Functions include on/off, forward/reverse, strokes per minute, throttle up/down, agitator on/off and horn.



Cable or optional radio remote.



Standard Engine Enclosures on all models provide security and safety on the job site.



Optional Hydraulically Driven Outriggers for operator convenience and quick set-up. Standard on SP 1250 and SP 2000.



Optional Water Pump is hydraulically driven and provides high flow for fast clean up.



Optional Auto-Greaser provides required lubrication and reduces maintenance labor while extending component life.



Hopper Agitator keeps harsher mixes flowing to the cylinders. Add optional **Hopper Vibrator** for optimum performance.



Order your SP trailer, truck, skid or track mounted.

SPECIFICATIONS

ROCK VALVE™ STATIONARY CONCRETE PUMPS

	SP 500		SP 750-15		SP 750-18	
	U.S.	Metric	U.S.	Metric	U.S.	Metric
Concrete Output Per Hour (cu. yds. - cu. m)	45	34	50	38	70	54
Maximum Pressure on Concrete (psi - bar)	1100	76	1100	76	1100	76
Maximum Aggregate Size (in. - mm)	1.5	38	1.5	38	1.5	38
Concrete Cylinder Diameter (in. - mm)	6	150	6	150	7	180
Differential Piston/Rod Diameter (in. - mm)	3.15/1.96	80/50	3.15/1.96	80/50	3.54/1.96	90/50
Concrete Cylinder Stroke Length (in. - mm)	39	1000	39	1000	39	1000
Maximum Pump Strokes Per Minute	32.5		35		35	
Main Hydraulic Pump	A11V095		A11V095		A11V0130	
Volume Control	0 to Maximum		0 to Maximum		0 to Maximum	
Concrete Valve Type	Long Rock™		Long Rock™		Long Rock™	
Shifting Cylinders	2		2		2	
Hydraulic Tank Capacity (gal - liters)	53	201	112	424	112	424
Hydraulic System	Open Loop		Open Loop		Open Loop	
Hopper Height (in. - mm)	50	1280	51	1292	51	1292
Hopper Capacity (cu. ft. - cu. m)	13	.38	13	.38	13	.38
Outlet Diameter (in. - mm)	5	125	5	125	5	125
Engine Model - Tier 4 Final	CAT 3.4B 74.5hp/55.6Kw		CAT 3.4B 100hp/74.6Kw		CAT 3.4B 100hp/74.6Kw	
Circuit Hydraulics	Twin Circuit: Accumulator		Twin Circuit: Accumulator		Twin Circuit: Accumulator	
Fuel Tank Capacity (gal - liters)	33.5	127	39	148	39	148
Axle	Single Standard		Tandem Standard		Tandem Standard	
Axle Capacity Rating (lbs. - kg)	8000	3629	11000	4990	11000	4990
Tires	ST 215/75 R17.5		-		-	
Tandem Axle Tire	ST 225/75 R15 (optional)		ST 235/80 R16 (std.)		ST 235/80 R16 (std.)	
Brakes	Electric		Electric		Electric	
Outrigger Legs	Manual Standard		Manual Standard		Manual Standard	
Length (ft.-in. - mm)	15-6	4712	16-5	4997	16-5	4997
Width (ft.-in. - mm)	6-2	1889	6-4	1950	6-4	1950
Height (ft.-in. - mm)	7-4	2226	8-6	2590	8-6	2590
Trailer Units Weight - Tier 4 Final (lbs. - kg)	7300	3311	8750	3969	8850	4014
Remote Control Cable (ft. - m)	100	30.5	100	30.5	100	30.5

Pump specifications are for standard units with standard equipment. Other units are available. Specifications are subject to change without prior notice.

SP 1000		SP 1000HP		SP 1250		SP 2000 (Rod/Piston)	
U.S.	Metric	U.S.	Metric	U.S.	Metric	U.S.	Metric
70	54	35	27	95	73	118/91	90/70
1100	76	1450	100	942	65	870/1566	60/108
1.5	38	.5	13	1.5	38	2.5	63.5
7	180	6	150	7	180	8	200
3.54/1.96	90/50	3.54/1.96	90/50	3.15/2.16	80/55	4.72/3.14	120/80
39	1000	39	1000	55	1400	63	1600
35		26		34		30/23	
A11V0130		A11V0130		A11VL0130		A11VL0190	
0 to Maximum		0 to Maximum		0 to Maximum		0 to Maximum	
Long Rock™		HP Short Rock		Long Rock™		M Rock	
2		2		2		2	
112	424	112	424	112	424	112	424
Open Loop		Open Loop		Open Loop		Open Loop	
51	1292	51	1292	51	1292	51	1294
13	.38	13	.38	13	.38	21	.60
5	125	4	100	5	125	7	180
CAT 4.4 137hp/102.2Kw		CAT 4.4 137hp/102.2Kw		CAT 4.4 173hp/129.5Kw		CAT 4.4 173hp/129.5Kw	
Twin Circuit: Accumulator		Twin Circuit: Accumulator		Twin Circuit: Accumulator		Single Circuit: No Accumulator	
39	148	39	148	53	200	53	200
Tandem Standard		Tandem Standard		Tandem Standard		Tandem Standard	
11000	4990	11000	4990	14000	6350	14000	6350
-		-		-		-	
ST 235/80 R16 (std.)		ST 235/80 R16 (std.)		LT 235/85R16 (std.)		LT235/85R16 (std.)	
Electric		Electric		Electric		Electric	
Manual Standard		Manual Standard		Hydraulic Standard		Hydraulic Standard	
16-5	4997	15-10	4835	20-1.5	6129	20-1.5	6129
6-4	1950	6-4	1950	6-4	1950	6-4	1950
7-11	2167	7-11	2167	7-11	2167	7-11	2167
9300	4218	9200	4173	10600	4808	13050	5919
100	30.5	100	30.5	100	30.5	100	30.5

OUTPUT CHARTS

ROCK VALVE™ STATIONARY CONCRETE PUMPS

SP 500

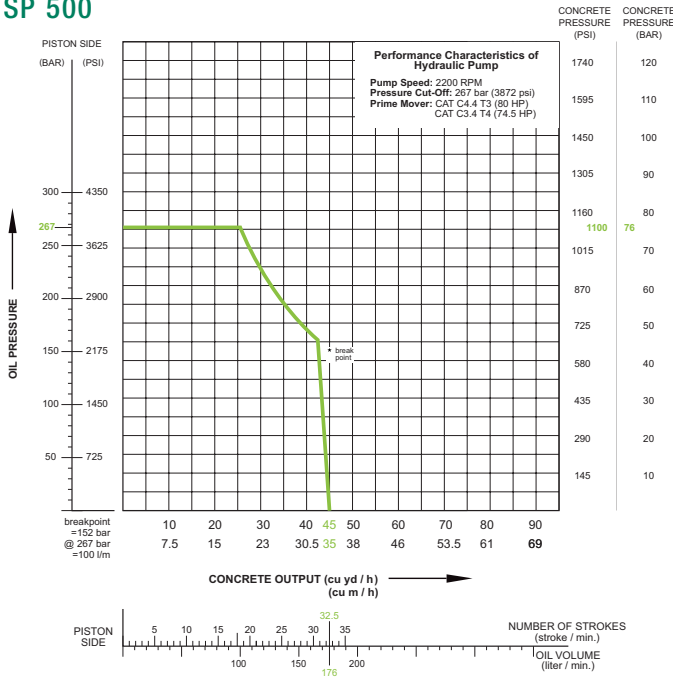

SP 750-15

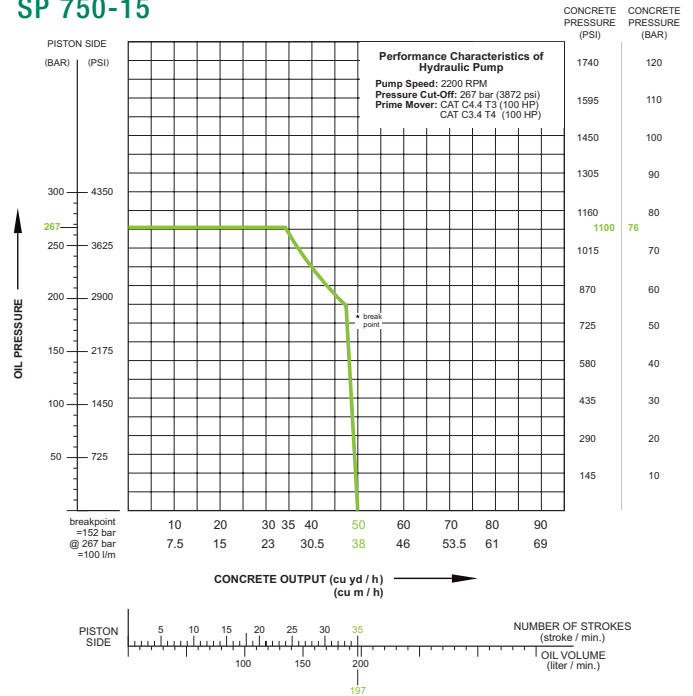

SP 1000HP

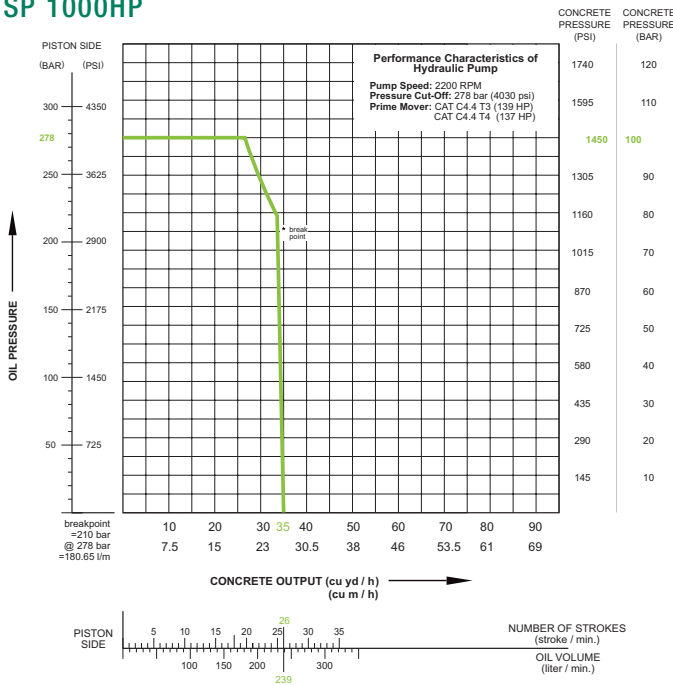

SP 1250

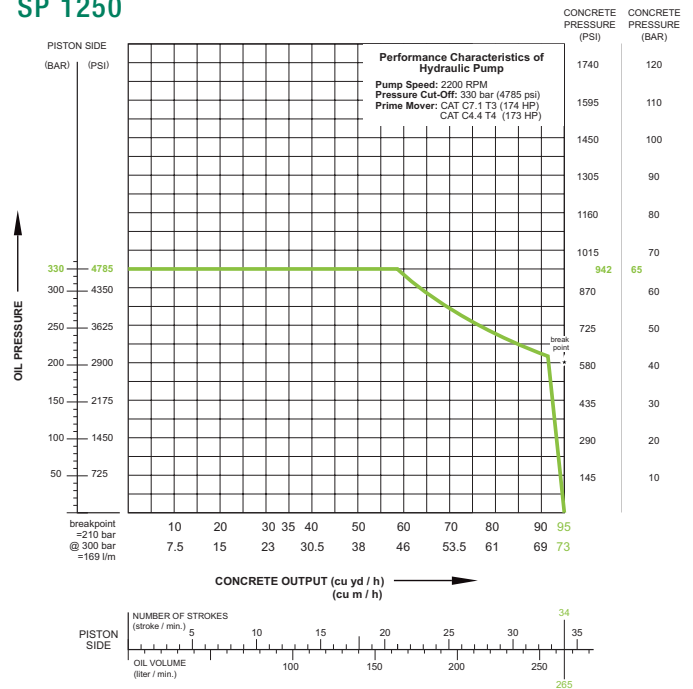

SP 750-18

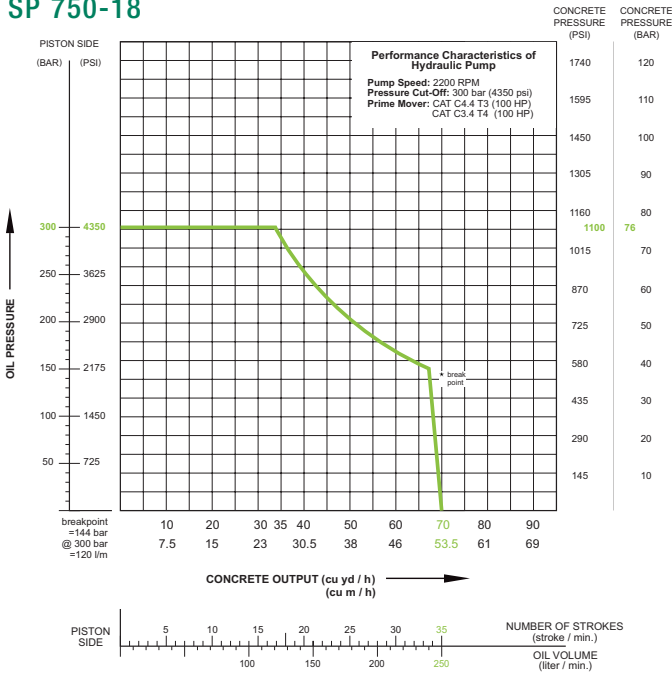

SP 1000

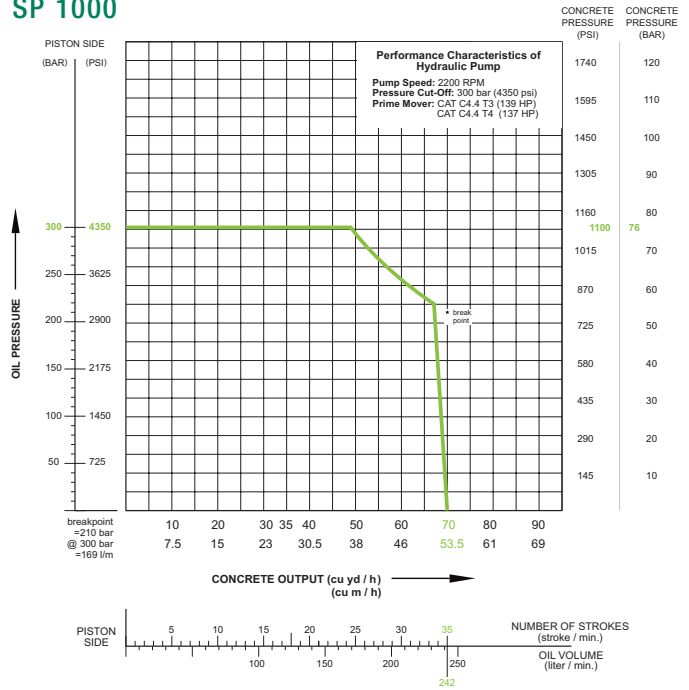

SP 2000

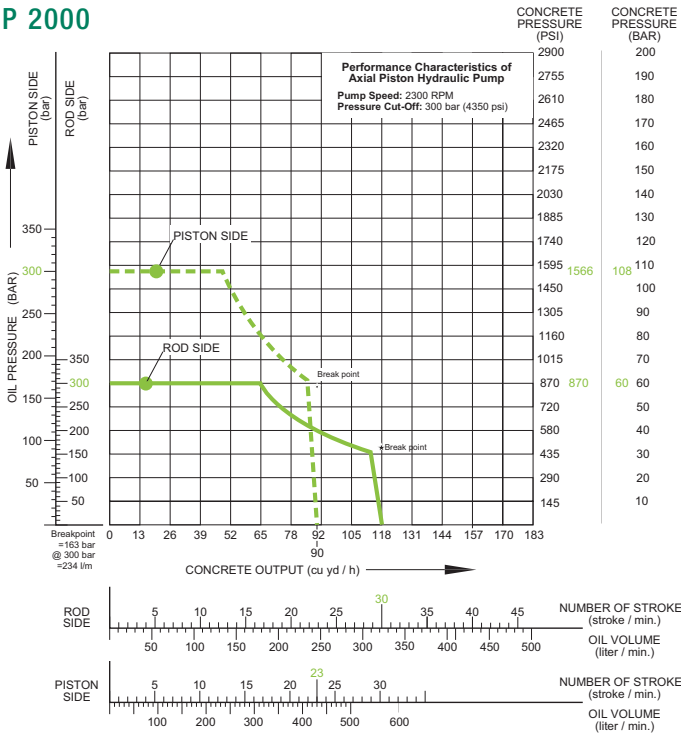

More than 400,000 square feet are devoted to producing the highest quality concrete equipment at our [White Bear, Minnesota](#) plant. From close inspection of incoming materials to forming our products with the latest robotic welding techniques, Schwing takes craftsmanship to the highest standards. Our state-of-the-art paint facility produces finished products you will be proud to put your name on. In addition, a vast inventory of parts are on hand to keep your Schwing product running at maximum efficiency. Please schedule a visit to this modern facility located minutes north of Minneapolis/St. Paul to see our long-term commitment to the market.



5900 Centerville Road | St. Paul, MN 55127 | TEL 1-888-SCHWING
FAX 651-429-3464 | www.schwing.com