**Putzmeister**

# Stationary concrete pump

# BSA 2110 HP D

Output up to 102 m<sup>3</sup>/h  
 Delivery pressure up to 220 bar

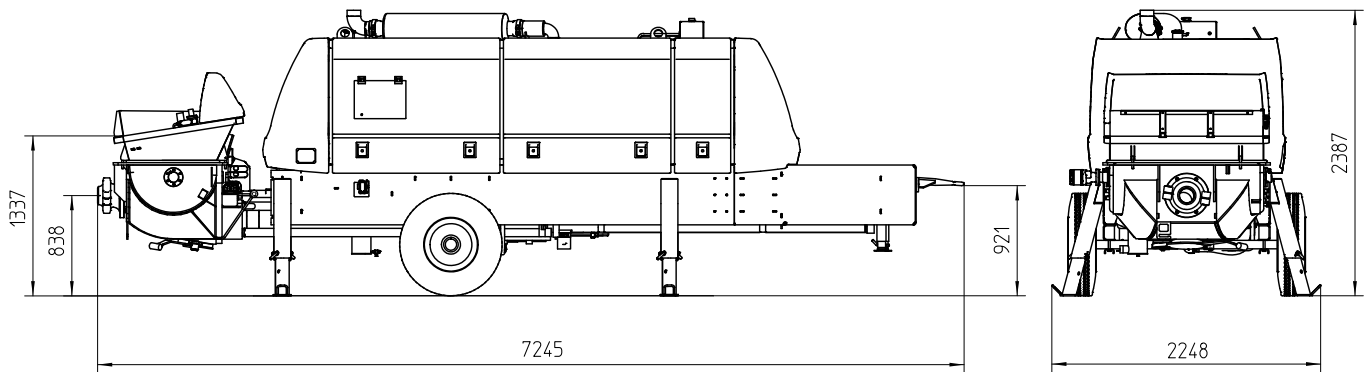

Note: Standard version BSA 2110 HP D. Dimensions and weights depend on equipment. Subject to technical modifications and errors.

## Technical data

Type		BSA 2110 HP D
Material number		102415.000
Output	m <sup>3</sup> /h	102 / 70 *
Delivery pressure	bar	150 / 220 *
Delivery cylinder	Ø mm	200
Delivery cyl. stroke	mm	2100
Strokes / minute		26 / 18 *
Engine / motor power	kW	330
Hopper		RS 905 HF
Capacity	l	approx. 600
Filling height	m	approx. 1.3
Transfer tube		S 1812 D
line connection	mm	ZX 125
Pressure connection	"	8
Control system		EPS FFH
Weight	kg	8800

\* Values for hydraulic fluid being fed to piston-side  
 All data maximum theoretical

## Serial equipment

Agitator safety switch off	Gate valve connection
Cable remote control 10 m	Grill 60 mm
Central lubrication on hopper with hand lever press	Hard metal wear parts
Cleaning accessories	Operating manuals (1× paper, 1× CD-ROM) spare part list
Coloring: Pump, frame, roof, tank and hood anthracite-grey Cover chrome yellow	Outriggers 4× mech.
Concrete hopper with agitator	Pump flow meter
Concrete output adjust	Set-up foot mech.
Concrete pressure adjust	Speed drawdown automatically on pump stop
Coupling ring (DIN)	Splash guard
Drive diesel, Deutz 330 kW	Tool set incl. standard equipment
Electronic error management	Trailer F8, travelling in site
Ergonic Graphic Display (EGD)	
Flushing water pump 160 l/min 25 bar	

See quotation for exact serial delivery scope.  
 Comprehensive range of options available on request.